

# 3 section three

## Fingerprint Image Quality Evaluation Methodologies



**As security awareness increases,** the deployments of automated biometric systems are increasingly popular everywhere in the world. An automated biometric system aims to assist or in certain applications, replace human in performing authentication through certain unique physiological or behavioural characteristics. However, many of the biometric systems today lack the ability to verify whether the presented sample carries valid and sufficient features to be processed. This article discusses the objectives and rationales behind the evaluation of fingerprint image quality with different approaches being explored. The effect of fingerprint image quality towards system performance is also included.

**Lim Eyung**  
Lecturer, Temasek Polytechnic  
Member, Biometric Technical Committee

### 1 Introduction

Being one of the earliest biometric technologies, fingerprint is an easily available identifier for each individual. Inked fingerprint image was captured on national identity card for this purpose. In those earlier days, authentication was done through manual comparison of captured fingerprints and inked records by trained personnel. Hence, fingerprint could be the most successful authentication technique in those days partly due to the lack of technology for capturing samples of other biometrics.

There are a few factors which contribute to the popularity of the fingerprint biometric technology. One of the main reasons is the inking method of fingerprinting as well as the recent advancement in fingerprint sensor technology has made fingerprinting easy to perform with high consistency and at low cost. Face recognition suffers from posture, expression and illumination problems. One's voice can also change considerably when the subject has just awakened from sleep, having a sore throat and so on. It is also practically hard to ask someone to speak in the same way as he did sometime ago when he was registered. Although the quality of fingerprint image is subject to change according to the condition of fingerprint and user behaviour, an averaged-quality fingerprint image will allow someone to be authenticated even in the dark or when the subject is ill. Moreover, the fingerprint pattern will not change considerably when someone grows old.

Thanks to the strong computation power available today, fingerprint authentication is almost immediate. This is in contrast to DNA authentication which takes hours to complete. Being one of the earliest biometric technologies, fingerprint has gained user acceptance through its application over the decades.

## 2 Common Problems in Fingerprint Biometric Systems

Automatic fingerprint identification system (AFIS) and automated fingerprint verification system (AFVS) are integrated systems that can handle fingerprint enrolment as well as identification/verification with minimum human attention. Enrolment or registration is the process of adding a known person's fingerprint record into the database while identification/verification is to perform feature matching between the query image and database entries/entry. Accessing rights to the facilities (e.g. door, computer system, etc.) will be issued according to the matching result. However, the identification as well as verification performance of such system is very sensitive to the quality of the captured fingerprint image.

Since AFIS and AFVS are expected to work independently and are exposed to potentially large number of users, the system would encounter issues such as dry, wet or dirty finger. In addition, some sensors have problems with residue and background noise. Although optical sensors have generally better image quality, some of the sensors have longer capture time which would not be able to capture a complete fingerprint image if the user removes his finger from the system before the capture is completed. Aging will also degrades one's fingerprint quality [1]. All these lead to "poor quality" images which could cause false rejection of an authorised user. On the other hand, residual images or attackers fingerprint images may also be of poor quality but allowing access to these would increase the false acceptance of the system. As a result, the system's performance is degraded. Therefore, it is vital for the AFIS and AFVS systems to gain information on the quality and validity of the captured fingerprint images so that they can work independently in a reliable manner.

## 3 Fingerprint Image Quality

Numerous past and on-going researches have contributed to the methodologies in fingerprint image quality evaluation. This document highlights some of them below:

### 3.1 Structure-Based Quality Measures

Quality Measures were defined based on the structural and signal point of view of a fingerprint image. Each of the defined quality measures caters for some aspects of the fingerprint quality but each might not work well for all fingerprint images when used alone. By combining all the quality measures, they give a more comprehensive estimation for the general spread of fingerprint images. Quality Measures can be sub-divided into the following:

#### 3.1.1 Direction-Based Method

As shown in Figure 1, an image sub-block generally consists of dark ridge lines separated by white valley lines of the same orientation. The consistent ridge orientation is therefore one of the distinguishable local characteristics of the fingerprint image.

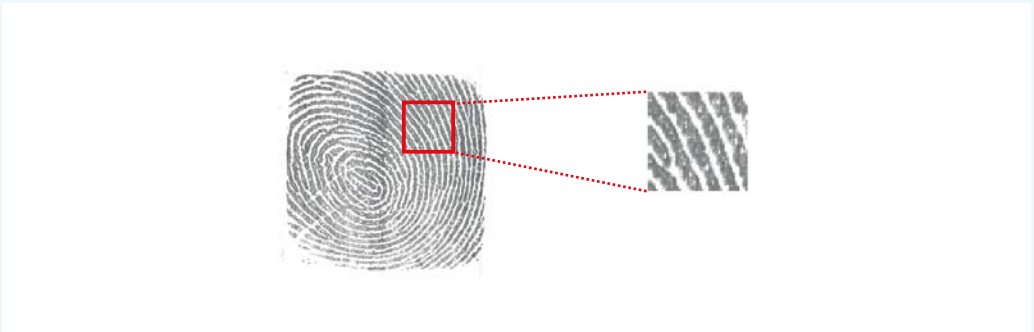

Figure 1: A typical texture-like ridge block

In [2], Bolle et. al. divided a fingerprint image into blocks of pixels. Each block is marked as directional or non-directional by searching for sufficiently large image gradient in some pre-defined directions. The blocks are also determined to be within the foreground or background of the image. The image quality measure is given by the area ratio of the selected contiguous to the total foreground area. Shen et. al. [3] applied Gabor filter to image sub-blocks, and concluded that a good quality block with clear repetition of ridge and valley pattern can be identified by the outputs of a Gabor filter bank. The authors make use of the fact that Gabor filter is a directional filter. The concentration of signal strength on one or a few filter bank output(s) implies that there is a strong directional field.

Kang et. al. [4] applied direction contrast method in their image quality measure. They applied three underlying ideas to reflect good fingerprints:

- (i) High contrast between ridges and valleys;
- (ii) Foreground for most of the image area; and
- (iii) Little scar or latency.

Eyung et. al. [5] defined Orientation Certainty Level using Principal Component Analysis to indicate the energy strength in the ridge-valley direction.

### 3.1.2 Sinusoidal Quality Measure

For each sub-block of image shown above, we can compute a signature along the x direction, positioned at the centre of each sub-block as shown below. The signature will pass through the centre of the image sub-block in the direction of x as shown in Figure 2.

Hong et. al. [6] classified a sub-block in an input fingerprint image as recoverable or unrecoverable region. Classification of blocks into recoverable and unrecoverable categories is performed based on the amplitude, frequency as well as variance that characterise the sinusoidal- or squared-shaped wave formed by local ridge and valley patterns. The method evaluates more aspects of the fingerprint image than simply directional strength.

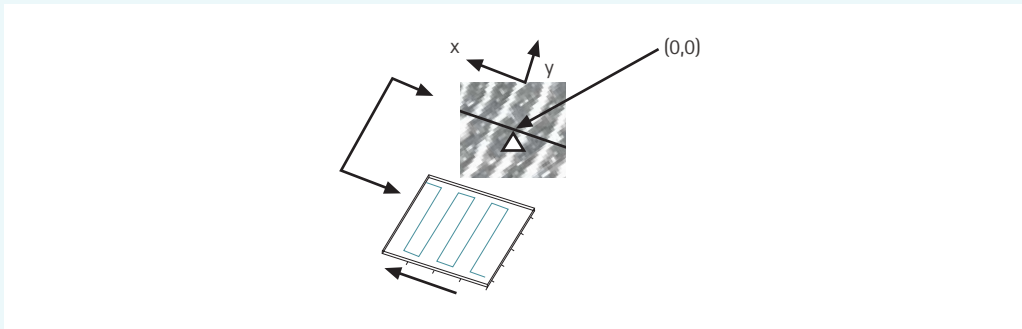

Figure 2: Signature along x direction

### 3.1.3 Other Measure

Ratha and Bolle [7] proposed a method for image quality estimation from a wavelet compressed fingerprint image. This is beneficial if the image to be processed is in Wavelet-packet Scalar Quantization (WSQ) compressed format.

### 3.2 Matcher-based Quality Evaluation

Human and machine may perceive "Quality" in different ways. A fingerprint image might "looked bad but the necessary information is still retrievable" by the fingerprint identification system. To reduce the difference, a quality evaluation system based on fingerprint matcher is applied.

Matcher-based Quality Evaluation System looks into how favourable a fingerprint image is viewed by the fingerprint matcher. A better scored match reflects that the fingerprint is of "high quality" in the eye of fingerprint matcher as it has more qualities that the fingerprint matcher requires. For a fingerprint image, average score from true matches were used as quality indicator. In the case of different fingers, the matching score would not be able to tell anything about the quality as the minutiae distribution is supposed to be different.

## 4 Experiment

Each fingerprint image in Database 1 with 2160 images is partitioned into 9 sub-blocks with its Quality Measures (QM) extracted. Each QM is obtained by selected measures from Section 3.1 above and form a QM Vector. The 9 QM Vectors forms 9 input vectors as 9 training samples to the classifier and they share the same target value. The target value is obtained through the following procedure:

- The fingerprint image has N other true matched targets (same person and same finger but different capture).
- The fingerprint is matched with all other N fingerprint images and the N matching scores obtained were averaged. The averaged score is the estimated matcher-based quality score (MBQ).

$$MBQ \text{ for } FS_{i,j,k}(m) = \frac{1}{N} \sum_{k=1}^9 Matching(F_{i,j,k}, F_{i,j,j}) , m=1,2,\dots,9 \quad (1)$$

where  $i$  : person index  
 $j$  : finger index  
 $k$  : capture index  
 $m$  : sub-block index  
 $FS_{i,j,k}(m)$  : Fingerprint Sub-block  $m$  of person  $i$ , finger  $j$ , capture  $k$ .  
 $F_{i,j,k}$  : Fingerprint of person  $i$ , finger  $j$ , capture  $k$ .  
 $Matching(A,B)$  : Returns a matching score of fingerprint  $A$  and  $B$ .

The procedure is repeated for all fingerprint images in Database 1 and this made up of a total of 9720 (2160\*9/2) training samples. A Reduced Multivariate Polynomial classifier (RMP)[8] which is reasonably accurate and fast is used to learn the concept.

A trained RMP classifier is able to predict the MBQ value of a fingerprint sub-block once its Quality Measure (QM) Vector is presented. The output from the traditional matching process is now given as

$$[MS \quad \overline{MBQ} \quad \hat{MBQ}] \quad (2)$$

where MS : matching score.

$$\overline{MBQ} = \frac{\sum_{k=1}^{18} MBQ(k)}{18} \quad \text{: Mean of the MBQ for all 9 sub-blocks from fingerprint A}$$

and 9 sub-blocks from fingerprint B.

$$\hat{MBQ} = \sqrt{\frac{1}{18} \sum_{k=1}^{18} (MBQ(k) - \overline{MBQ})^2} \quad \text{: Standard Deviation of the MBQ for all 9 sub-blocks from fingerprint A and 9 sub-blocks from fingerprint B.}$$

### Experiment Setup

RMP is again chosen as the classifier to perform experiments on Matcher-based Quality Evaluation. There are two training phases of classification process needed.

Firstly, given the Quality Measures for each of the fingerprint image sub-blocks as input vector and the MBQ as output vector, the first RMP classifier is trained to learn the MBQ estimation. In the second phase, the MBQ estimation from the first phase is used in a matching pair and input vector is formed using equation (2). The output of the second phase is provided by a match/non-match feature value. Another RMP is applied to learn the match/non-match judgment.

The training phase depicted above is carried out using Database 1. During the testing phase, Database 2 of size 2160 which has never been presented to the system is used.

## 5 Results

The results were plotted in Figure 3 and Figure 4. (For orders a-b, a refers to Quality Assignment Phase Order and b refers to Matching Phase Order).

For the figures below, the red curves represent the original receiving operating characteristics (ROC) plots without inclusion of Matcher-based Quality Score while the blue ones are the new ROC plots with Matcher-based Quality Score. Improvement in the ROC curve can be observed by the position of the new curve which is higher than the original one.

Figure 1 and Figure 2 are very good examples of how the inclusion of Matcher-based Quality Score can improve the accuracy of a Fingerprint Identification System. For any setting on the x-axis which is the False Acceptance Rate of the system, the new ROC has a better Authentic Acceptance Rate than the original curve. This indicates an overall system performance improvement.

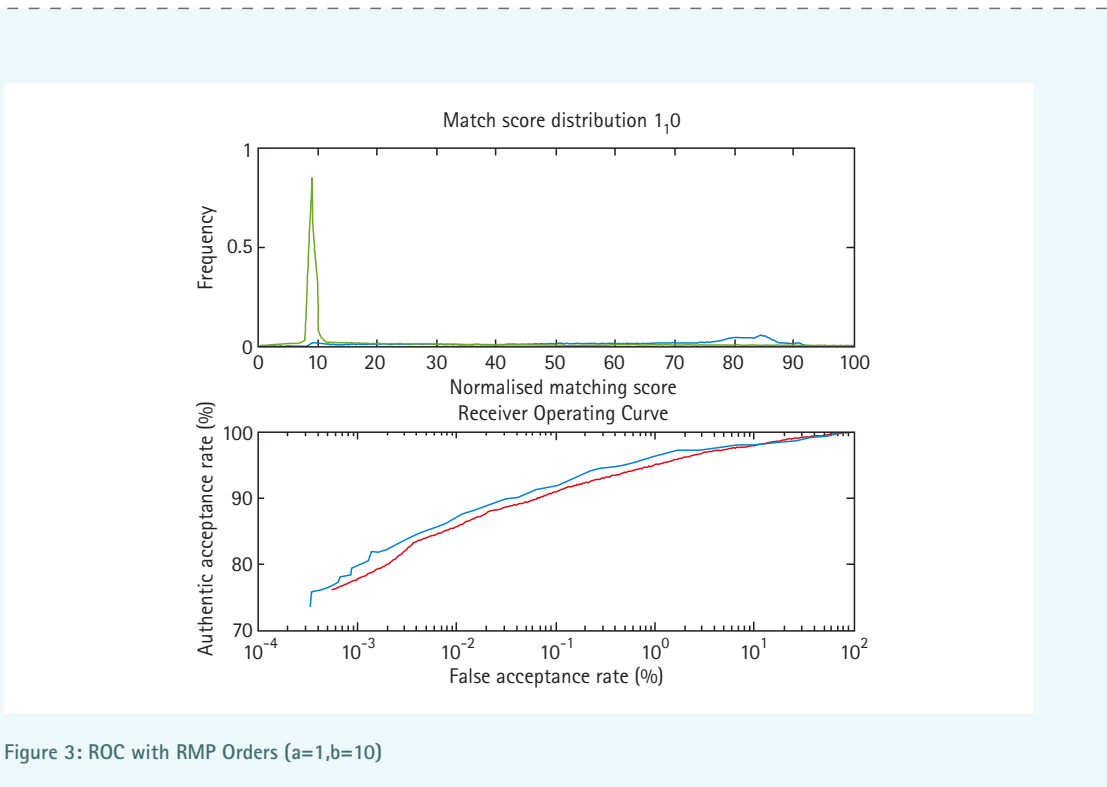

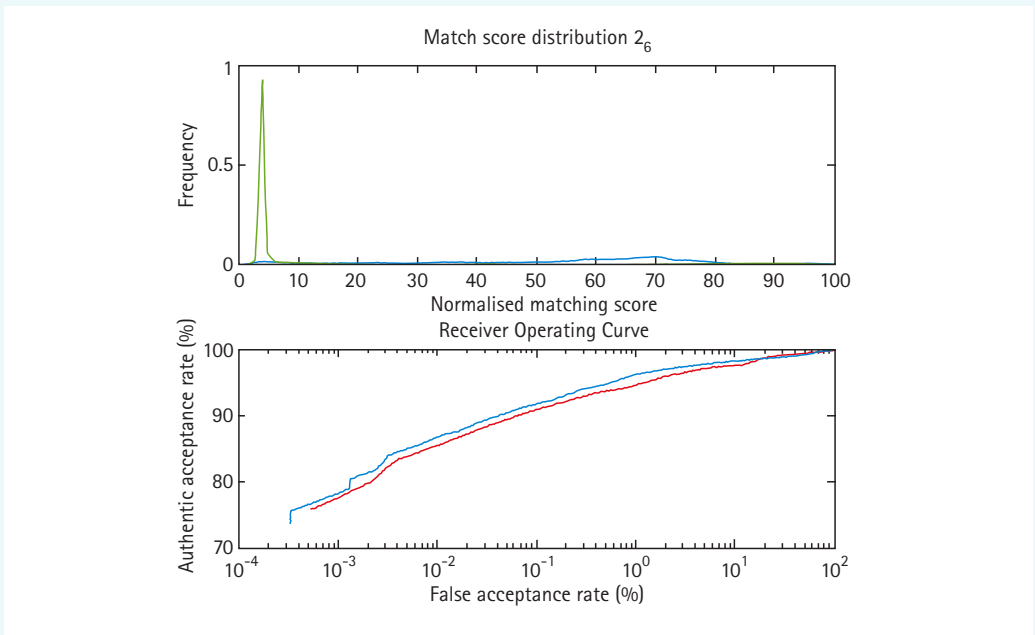

Figure 4: ROC with RMP Orders (a=2,b=6)

## 6 Standardisation

Despite the numerous efforts and advancement in using Fingerprint Quality as a tool to enhance system performance, there is no formal standard for fingerprint image quality measurement. The closest currently available specification would be the Minimum Image Quality Requirements published by FBI, which is meant for the rolled-impression fingerprints collection. However, the processes of feature extraction, matching, and even quality evaluation is still very much vendor specific. The ISO/IEC JTC1 SC 37 Working Group 3 is currently looking at the standardisation of Biometric Sample Quality under project 29794, with another part, 29794-4 looking into specifically finger image quality normalisation.

## 7 Conclusion

With the proliferation of biometrics applications, there is a timely needed in the standardisation of the biometric sample's quality. Researches and studies have indicated that better system accuracy is achieved by the use of quality evaluation in the fingerprint matching algorithm.

## 8 References

- [1] Sickler N. C. and Elliott S. J., "An Evaluation of Fingerprint Quality across an Elderly Population vis-à-vis 18-25 Year Olds", 4th Annual CERIAS Research Symposium, Purdue Memorial Union & Stewart Center, West Lafayette Campus, April 2003.
- [2] Bolle et al, "System and method for determining the quality of fingerprint images", United State Patent number, US596356, 1999.
- [3] L.L.Shen, A. Kot and W.M Koo, "Quality Measures of Fingerprint Images", 3rd International Conference AVBPA 2001, p182-271, June 2001.
- [4] Kang H., Lee B, Kim H., Shin D. and Kim J., "A Study on Performance Evaluation of Fingerprint Sensors", 4th International Conference on Audio- and Video-based Biometric Person Authentication, University of Surrey, Guildford, UK, June 2003.
- [5] E. Lim, X.D. Jiang, W.Y. Yau, "Fingerprint Quality and Validity Analysis", International Conference on Image Processing, New York, September 2002.
- [6] L.Hong, Y.Wan and A.K.Jain, "Fingerprint Image Enhancement: Algorithm and Performance Evaluation", IEEE Transaction on Pattern Analysis and Machine Intelligence, vol.20, no.8, August 1998.
- [7] Nalini K. Ratha and Ruud M. Bolle, "Fingerprint Image Quality Estimation", IBM Computer Science Research Report RC 21622, 1999.
- [8] K.-A. Toh, W.-Y. Yau and X. Jiang, "A Reduced Multivariate Polynomial Model For Multimodal Biometrics And Classifiers Fusion", IEEE Trans. on Circuits and Systems for Video Technology (Special Issue on Image- and Video-Based Biometrics), vol.14, no.2, pp.224-233, 2004.